



USER MANUAL

CORDLESS JIGSAW 12V



FERREX®

AFTER SALES SUPPORT

859070

GB

☎ 0 1827 438 013

📧 SERVICE-UK@PROTEL-SERVICE.COM

IE

☎ 0 124 695 20

📧 SERVICE-UK@PROTEL-SERVICE.COM

MODEL: FBT-CJS004

05/2026

3
YEAR WARRANTY

ORIGINAL INSTRUCTION MANUAL

CONTENT

1 General	3
2 Safety	3
2.1 Explanation of signal words	3
2.2 Explanation of symbols	3
2.3 General safety instructions for power tools	3
2.4 Safety instructions for jigsaws	5
2.5 Additional safety instructions	5
2.6 Additional safety instructions for jigsaws	5
2.7 Before use	5
2.8 During use	5
2.9 Additional safety instructions for batteries and chargers	5
2.10 Intended use	6
3 Scope of delivery	6
4 Product components	7
5 Before first use	7
5.1 Check product and scope of delivery	7
5.2 Basic cleaning	7
6 Use	7
6.1 Battery	7
6.2 Switching on/off	7
6.3 Inserting a saw blade	7
6.4 Adjusting the pendulum action	7
6.5 Making bevel cuts	8
6.6 Parallel guide	8
6.7 Connecting the dust extraction system	8
6.8 Saw blade types	8
6.9 LED lighting	8
7 Accessories	8
8 Cleaning and maintenance	8
8.1 Cleaning	8
8.2 Maintenance	8
8.3 Storage	8
8.4 Transport	8
9 Technical data	9
9.1 Charging via USB	9
10 Waste disposal and recycling	9
10.1 Disposing of the packaging	9
10.2 Disposing of the Product	9
10.3 Battery disposal	9
11 EC Declaration of Conformity	10
12 UK Declaration of Conformity	10
13 Warranty	10

1 GENERAL



User manuals provide useful tips on how to use your new device. They help you to use all the functions, prevent misunderstandings, and avoid damage. Please take the time to read this manual carefully and keep it as a

reference.

Please read all safety instructions!

This manual contains important information about operating and handling the device. Keep this user manual for future reference. Please pass it on together with the device if it is handed over to third parties. This manual is available in PDF format at www.ferrex12vpower.com.

2 SAFETY

2.1 EXPLANATION OF SIGNAL WORDS

The following signal words are used in this manual, on the product, and/or on the packaging.

DANGER!

- » This signal word indicates a hazardous situation which, if not avoided, will result in death or serious injury.

WARNING!

- » This signal word indicates a hazardous situation which, if not avoided, could result in death or serious injury.

CAUTION!

- » This signal word indicates a hazardous situation which, if not avoided, could result in minor or moderate injury.

CAUTION!

- » This signal word indicates a hazardous situation which, if not avoided, could result in property damage.

NOTE

- » This signal word is a preferred signal word for tips and practices that are not related to personal injury.

2.2 EXPLANATION OF SYMBOLS

The following symbols are used in the user manual or on the product:



WARNING – Read the instructions to reduce the risk of injury.



Always wear hearing protection. Exposure to noise may cause hearing damage.



Wear safety glasses. Sparks generated during operation, or splinters, chips, and dust from the machine can cause eye damage.



Wear a dust mask. When working with wood and other materials, dust may be released that is harmful to health. Materials containing asbestos must not be processed!



0-40°C

Do not expose the battery to temperatures above 40 °C.



Do not expose the battery to fire. Explosion hazard!



Prevent the battery from coming into contact with water. Do not immerse the battery in water. Explosion hazard!



The "Tested Safety" seal (GS mark) confirms that the product complies with the Product Safety Act (ProdSG) and is safe when used in a foreseeable and intended manner.



CE stands for: "Conformité Européenne". This means: "Complies with EU directives". With the CE mark, the manufacturer confirms that this machine complies with the applicable European directives.



UKCA stands for: "UK Conformity Assessment". This means "Compliant with UK regulations". With the UKCA mark manufacturer confirms that this unit complies with the applicable UK regulations.



The machine must not be disposed of with household waste.

2.3 GENERAL SAFETY INSTRUCTIONS FOR POWER TOOLS

WARNING!

- » Incorrect handling of the product can lead to injuries.

WARNING!

- » **Warning! Read all instructions carefully.** Failure to follow the instructions below may result in electric shock, fire, and/or serious personal injury.
- » **Keep these instructions!**

The term "power tool" in the warnings below refers to both corded and cordless (battery-operated) equipment.

2.3.1 WORK AREA

- Ensure a tidy and well-lit working environment.** Cluttered and dark work areas lead to accidents.
- Never use power tools in an environment where there is a risk of explosion, such as in the vicinity of flammable liquids, gases, vapors, or other substances.** Power tools can cause sparks, which can ignite these substances.
- When using power tools, keep children and bystanders away.** Distractions can cause you to lose control of the tool.



2.3.2 ELECTRICAL SAFETY

- a) **Power tool plugs should fit securely into the outlet. Never modify the plug or the outlet. Do not use adapters for grounded power tools.** Standard plugs and matching sockets reduce the risk of electric shock.
- b) **Avoid physical contact with grounded surfaces such as pipes, conduits, radiators, stoves, and refrigerators.** When your body is grounded, the risk of electric shock increases.
- c) **Never expose power tools to rain or moisture.** If water gets into an electric tool, the risk of electric shock increases.
- d) **Do not use the cord to carry, move, or unplug the power tool. Protect the cord from oil, heat, sharp edges, and moving parts.** Damaged or snagged cords increase the risk of electric shock.
- e) **When using power tools outdoors, use an extension cord that is suitable for outdoor use.** Using a cord suitable for outdoor use reduces the risk of electric shock.
- f) **Always use electrical equipment in combination with a residual current device.** The use of a residual current device reduces the risk of electric shock.

2.3.3 PERSONAL SAFETY

- a) **Always stay alert, watch what you are doing, and use common sense when using power tools. Do not use power tools when you are tired or have used drugs, alcohol, or medication.** A moment of inattention when using power tools can result in serious injury.
- b) **Use safety devices. Always wear safety glasses.** Proper use of safety equipment, such as a dust mask, special work shoes with non-slip soles, a safety helmet, and hearing protection, reduces the risk of personal injury.
- c) **Prevent the tool from being started accidentally. Ensure the switch is in the OFF position before connecting the device to the power source and/or battery, and before picking up or carrying the device.** Never carry power tools with your finger on the switch, and never plug in power tools that are switched on: this leads to accidents.
- d) **Remove all adjustment and other keys from the power tool before switching it on.** Adjusting and other keys on a rotating part of the power tool can cause injuries.
- e) **Make sure you never lose your balance; always keep both feet firmly on the floor.** This will help you control the power tool in unexpected situations.
- f) **Wear suitable clothing. Do not wear loose clothing or jewelry. Keep your hair, clothing, and gloves away from moving parts.** Loose clothing, jewelry, and long hair can get caught in moving parts.
- g) **When provisions are made for the connection of dust extraction systems, ensure that they are connected and used correctly.** Using these provisions reduces the hazards caused by dust.
- h) **Do not give yourself a false sense of security and do not ignore the safety rules for power tools, even if you are familiar with the power tool after repeated use.** Careless operation can cause serious injury in a fraction of a second.

2.3.4 USE AND MAINTENANCE OF POWER TOOLS

- a) **Do not force power tools. Use the right tool for your specific application.** The right power tool will do the job better and safer at the speed for which it was designed.
- b) **Never use power tools with a faulty ON/OFF switch.** Any power tool that cannot be turned on and off with the switch is dangerous and must be repaired.
- c) **Unplug the power cord and/or remove the battery, if it can be removed, from the power tool before making adjustments, changing accessories, or storing the power tool.** Following these preventive safety measures will reduce the risk of the tool starting accidentally.
- d) **Store power tools that are not in use out of the reach of children and do not allow persons unfamiliar with the tool or these instructions to use the device.** Power tools are dangerous in the hands of untrained users.
- e) **Maintain power tools properly. Check that moving parts are properly secured. Also check that there are no defective parts or other conditions that could affect the operation of the tool. If the tool is damaged, have it repaired before use.** Many accidents are caused by poor tool maintenance.
- f) **Ensure that cutting and sawing tools remain sharp and clean.** Well-maintained cutting and sawing tools with sharp edges are less likely to jam and are easier to control.
- g) **Use all power tools, accessories, bits, etc., as specified in these instructions and in the manner for which the tool is designed. Take into account the working conditions and the task to be performed.** Using power tools for tasks other than those for which they are designed can lead to dangerous situations.
- h) **Keep handles and grips dry, clean, and free of oil and grease.** Slippery handles and grips make it impossible to handle and control the tool safely in unexpected situations.

2.3.5 USE AND MAINTENANCE OF BATTERY-POWERED TOOLS

- a) **Only recharge with the battery charger specified by the manufacturer.** A battery charger that is suitable for one type of battery pack may pose a fire hazard when used with another battery pack.
- b) **Only use electric machines with battery packs specifically designed for them.** The use of other battery packs may pose a risk of injury and fire.
- c) **When not in use, keep the battery pack away from other metal objects, such as paper clips, coins, keys, nails, screws, or other small metal objects that could create a connection between the two battery terminals.** Short circuits between the battery terminals can cause burn marks or fire.
- d) **If used incorrectly, liquid may leak from the battery; avoid contact with it. If you accidentally come into contact with it, rinse the area with water. Also seek medical attention if the fluid comes into contact with your eyes.** Fluid from the battery can cause irritation or burns.
- e) **Do not use a battery or tool that is damaged or modified.** Damaged or modified batteries may exhibit unpredictable behavior that could result in fire, explosion, or injury.



- f) **Do not expose a battery or tool to fire or excessive temperatures.** Exposure to fire or temperatures above 130°C may cause an explosion.
- g) **Follow all charging instructions and do not charge the battery or tool outside the temperature range specified in the instructions.** Incorrect charging or charging at a temperature outside the specified range may damage the battery and increase the risk of fire.

2.3.6 SERVICE

- a) **Contact a qualified specialist who uses original parts when repairing your power tool.** This ensures proper operation of the device.
- b) **Never perform maintenance on damaged batteries yourself.** Battery maintenance should only be performed by the manufacturer or authorized service providers.

2.4 SAFETY INSTRUCTIONS FOR JIGSAWS

- a) **Hold the power tool by the insulated handles when performing work where the accessory may come into contact with hidden wiring.** If the accessory comes into contact with a live wire, the metal parts of the power tool may become live and the user may receive an electric shock.
- b) **Use clamps or other practical means to secure and support the workpiece on a stable platform.** Holding the workpiece by hand or against your body leads to instability and may result in loss of control.

2.5 ADDITIONAL SAFETY INSTRUCTIONS

- Read this manual carefully and use the device only in accordance with this manual.
- Dispose of used packaging material carefully or keep it out of the reach of children. There is a risk of suffocation!
- Persons with physical, sensory, or mental disabilities should not use the device unless they are supervised and instructed on safety by a qualified person.
- The device is not a toy and should not be used by children. Never leave the device unattended when in use. Keep it out of the reach of children or persons who need supervision. Children must always be supervised to ensure that they do not play with the device.
- Do not cut or saw in areas where there may be hidden electrical, gas, or water pipes.
- Regularly check all nuts, bolts, and other fasteners and tighten them if necessary.
- Do not continue to use the device if it becomes damaged; have it repaired by an expert or contact our customer service department. Do not disassemble the device or attempt to repair it yourself.
- Do not let familiarity with the tool through frequent use tempt you to become so complacent
- that you ignore the safety principles of the tool. A careless action can cause serious injury in a fraction of a second.
- Keep the handles and surfaces you grip dry, clean, and free of oil and grease. Slippery handles and surfaces you grip can prevent you from safely handling and controlling the tool in unexpected situations.

- Hold the power tool by the insulated handles when performing an operation where the saw blade may come into contact with hidden wiring. Contact with a "live" wire will also cause exposed metal parts of the power tool to become "live," which may result in the user receiving an electric shock.
- Use clamps or other practical means to securely fasten the workpiece and support it on a stable surface. If you hold the workpiece with your hand or against your body, it will remain unstable and you may lose control of it.

2.6 ADDITIONAL SAFETY INSTRUCTIONS FOR JIGSAWS

- Only use saw blades that are suitable for this model. Do not work with blunt, damaged, or bent saw blades. Ensure that the saw blade is securely fastened before turning on the device.
- Do not attempt to cut workpieces so small that they cannot be securely fastened. Do not support the workpiece with your hand or foot. There is a risk of kickback from the device! Do not reach over the front of the device with your hands and do not place either hand near the saw blade, e.g. to remove loose splinters, chips/shavings or jammed workpiece fragments.
- Always remove the battery from the device when it is not in use, before performing maintenance or before changing the saw blade.
- For your own safety, wear safety goggles, a dust mask, and hearing protection.
- Make sure that there are no nails, screws, or similar objects in the workpiece.

2.7 BEFORE USE

- Report any damage caused by screws, nails, and similar items on your workpiece; remove them before starting work.
- Use suitable detection equipment to locate hidden utility lines or consult the local utility company (contact with electrical lines can cause fire and electric shock; damage to a gas line can cause an explosion; intrusion into a water line causes property damage or can cause electric shock).
- Secure the workpiece (a workpiece held in place with clamps or a vise is safer than a workpiece held by hand).

2.8 DURING USE

- Hold the power tool by the insulated gripping surfaces **8** when performing work where the accessory or screw may come into contact with hidden electrical wiring (contact with a live wire may also energize metal parts of the power tool and cause an electric shock).
- In the event of atypical behavior or strange noises, switch off the device immediately or unplug the charger from the power outlet.

2.9 ADDITIONAL SAFETY INSTRUCTIONS FOR BATTERIES AND CHARGERS

When using power tools, the following safety precautions must always be observed to prevent electric shock, injury, and/or fire. Read and pay close attention to these recommendations before using a machine.

2.9.1 BATTERIES

WARNING!

- » Improper use of the battery can lead to fire, explosion, or other hazards.
- » Battery fluid can cause serious injury or damage to property. If battery fluid comes into contact with the skin, rinse the skin immediately with water. If a red rash, pain, or irritation occurs, consult a doctor immediately. If battery fluid comes into contact with the eyes, rinse the eyes immediately with water.

- Never attempt to open a battery.
- Do not expose the battery to water.
- Do not expose the battery to heat sources.
- Do not store batteries in places where the temperature may exceed 40 °C.
- Keep batteries out of the reach of children.
- Only charge batteries at an ambient temperature between 10 °C and 40 °C.
- Only charge the battery with the charger (FBT-CLC011) or the supplied USB-C charging cable.
- Only use the batteries intended for use in the power tools. Using other batteries may result in injury and fire hazard.
- When disposing of batteries, follow the instructions in the section "WASTE DISPOSAL AND RECYCLING."
- Do not damage or deform the battery by puncturing it or subjecting it to impact, as this may result in injury and fire hazard.
- Do not charge damaged batteries.
- Be extra careful with the battery. Do not drop it on a hard surface and do not subject it to pressure or any other form of mechanical stress. Keep the battery away from extreme heat and cold.
- Important! Danger! Never short-circuit the battery or expose it to moisture. Do not store the battery together with metal parts that could cause the contacts to short-circuit. The battery may overheat, catch fire, or explode.
- The battery cells in the battery pack are not replaceable.

Under extreme conditions of use, liquid may leak from the battery. If you notice liquid on the batteries, carefully remove the liquid from the battery using a cloth. Avoid skin contact. If the liquid does come into contact with the skin or eyes, follow the instructions above.

2.9.2 CHARGERS

NOTE

- » Important! USB charger or fast charger are not included.
- » Recommended charging values: 5.0V d.c. / 1.8 A (type C).

The charger is designed for a specific voltage. Always check that the mains voltage corresponds to the voltage on the type plate.

WARNING!

- » Unplug the charger from the wall outlet when not in use and before cleaning and maintenance.

- Never replace the charger with a mains plug.
- Only use the charger to charge the included battery or batteries purchased specifically for the machine. Other batteries may rupture, causing injury and property damage.
- Never attempt to charge non-rechargeable batteries.
- Have a damaged power cord replaced by the manufacturer or an authorized service center to prevent hazards.
- Do not expose the charger to water.
- Do not open the charger.
- Do not puncture the charger.
- The machine/battery must be placed in a well-ventilated area during charging.
- The charger is intended for indoor use only.

2.10 INTENDED USE

This tool is intended for sawing. This battery-powered jigsaw may only be used in private households. The machine may only be used for the work for which it is intended.

- Only use the product as described in these instructions. Any other use is considered improper and may result in material damage or even personal injury.
- Possible injury if used incorrectly.
- The manufacturer or dealer accepts no liability for damage caused by improper or incorrect use.

3 SCOPE OF DELIVERY

- 1× Cordless jigsaw
- 1× Battery
- 1× USB-C charging cable
- 1× Saw blade for wood
- 1× Saw blade for metal
- 1× Dust extraction adapter
- 1× Parallel guide
- 1× Allen key
- 1× User manual

4 PRODUCT COMPONENTS

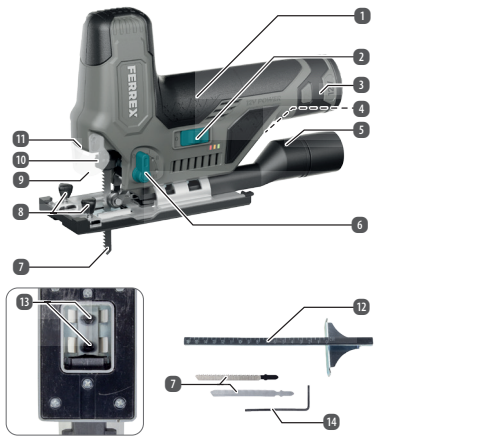

- | | |
|----------------------------------|---------------------------------|
| 1. Handle | 9. Transparent protective cover |
| 2. On/Off switch | 10. Saw blade holder lock |
| 3. Battery | 11. LED lighting |
| 4. Speed control | 12. Parallel guide |
| 5. Dust extraction adapter | 13. Allen screws |
| 6. Switch for pendulum positions | 14. Allen wrench |
| 7. Saw blade | |
| 8. Fastening latches | |

5 BEFORE FIRST USE

5.1 CHECK PRODUCT AND SCOPE OF DELIVERY

⚠ WARNING! SUFFOCATION HAZARD!

» Keep all packaging materials away from children and pets; these materials are a potential source of danger, as you could suffocate on them or swallow small parts.

CAUTION! RISK OF INJURY!

» Be careful when opening the packaging to avoid damaging the product. Avoid using sharp objects.

1. Remove the product from the packaging.
2. Remove the packaging material and all plastic/protective films.
3. Check that the delivery is complete (see **PRODUCT OVERVIEW** section).
4. Check the product or individual parts for damage. If this is the case, do not use the product. Please contact the service center using the contact details provided on the front page of this manual.

5.2 BASIC CLEANING

Before first use, clean all parts of the product as described in the **CLEANING AND MAINTENANCE** section.

6 USE

6.1 BATTERY

6.1.1 INSERTING THE BATTERY

Slide the charged battery into the battery holder until it clicks into place.

6.1.2 REMOVING THE BATTERY

To remove the battery, press the battery release buttons and pull the battery out of the power tool. Do not use force.

6.2 SWITCHING ON/OFF

Make sure you can press the on/off switch without letting go of the handle.

- a) To switch on the power tool, slide the on/off switch **2** forward so that "I" appears on the switch.
- b) To turn off the power tool, slide the on/off switch **2** backward so that "0" appears on the switch.

6.3 INSERTING A SAW BLADE

- a) Disconnect the device from the battery before performing any work on the device.
- b) To insert the saw blade, first lift the transparent protective cover **9**.
- c) Release the saw blade holder lock **10** by turning it until the saw blade can be inserted into the holder.
- d) Then allow the saw blade holder lock **10** to spring back and the saw blade will be securely fastened.
- e) Then fold the transparent protective cover back down. The transparent protective cover must always be used.

⚠ CAUTION!

» Please note: The saw blade becomes very hot during sawing due to friction. Keep this in mind when removing the saw blade. Protect yourself with safety gloves if necessary.

6.4 ADJUSTING THE PENDULUM ACTION

The pendulum action is adjusted using the pendulum position switch **6**. The pendulum action gives the saw blade a horizontal forward movement. At level 0, the saw blade does not move forward; the greatest forward movement is at level 3. During the downward stroke, the saw blade is pushed backward to facilitate the removal of sawdust. This increases the longitudinal cutting speed and reduces the energy required during cutting. It also increases the service life of the saw blade.

6.4.1 FOR SAWING

- a) Metal, set the pendulum movement to 0 or 1.
- b) HDF board, plywood, and plastic: set the pendulum movement to 1 or 2.

- c) Hard and soft wood, chipboard, and MDF: set the pendulum action to 1, 2, or 3.

The harder the material to be sawn, the smaller the pendulum movement should be, and the softer the material, the larger the pendulum movement should be set.

CAUTION!

- » As a result of the extra vertical movement, the cut edges are more frayed than when working without pendulum action. The surface finish of wood-based panels tends to fray, especially when working with extra pendulum action, due to their fire-resistant structure.

6.5 MAKING BEVEL CUTS

You can make miter cuts up to 45° with this saw by tilting the angle of the base plate.

- First, loosen the two Allen screws **14** in the central opening of the base plate using the Allen key **13** provided.
- After loosening, push the base plate slightly backward until the metal teeth of the housing come loose from the base plate.
- You can now set the base plate to the desired angle.
- Secure it in this position by pushing it forward and retightening the Allen screws.

6.6 PARALLEL GUIDE

Use the rip fence **12** for parallel guidance along the edge of a workpiece.

- Install the rip fence by sliding it through the locks **8** in the base plate. The centimeter scale on the rip fence allows you to precisely set the distance between the edge and the saw blade.
- The rip fence can then be secured to the base plate with the screws.

6.7 CONNECTING THE DUST EXTRACTION SYSTEM

Insert the dust extraction adapter **5** into the recess in the base plate. Connect a suction hose to the dust extraction adapter **5**. Connect the suction hose to a vacuum cleaner.

6.8 SAW BLADE TYPES

- Only use jigsaw blades with a T-shank.

6.9 LED LIGHTING

The LED light **11** comes on automatically as soon as you press the On/Off switch **2**.

7 ACCESSORIES

Only use accessories with a permitted speed that is at least as high as the highest no-load speed of the machine.

8 CLEANING AND MAINTENANCE

8.1 CLEANING

⚠ CAUTION! RISK OF SHORT CIRCUIT!

- » Remove the battery from the product before cleaning.

⚠ WARNING! RISK OF ELECTRIC SHOCK OR SHORT CIRCUIT

- » Never immerse the product in water or other liquids. Ensure that no water or other liquids enter the housing.

CAUTION! RISK OF DAMAGE!

- » Do not use aggressive cleaning agents, brushes with metal or nylon bristles, or sharp or metal cleaning objects such as knives, hard spatulas, and the like. These can damage the surfaces of the product.

8.2 MAINTENANCE

⚠ WARNING! RISK OF ELECTRIC SHOCK!

- » Remove the battery from the product before performing maintenance. Any maintenance other than that specified in this manual must be carried out by a professional repair center. Contact customer service for maintenance.

8.3 STORAGE

CAUTION! RISK OF DAMAGE!

- » Avoid and protect the product from dust, water, moisture, frost, extreme temperatures, high humidity, and direct sunlight.

- Before storage, clean all parts as described in the **CLEANING AND MAINTENANCE** section.
- Dry the product completely before storing it.
- Always store the product in a cool and dry place, with an ambient temperature between 5°C and 20°C.
- Keep the product out of the reach of children and pets.

8.4 TRANSPORT

- Protect the product from vibrations or shocks, e.g. when transporting it in vehicles.
- Secure the product against slipping. Secure the product against slipping. Use bungee cords, ratchet straps, or similar means.

9 TECHNICAL DATA

Stroke frequency:	500 – 2800 min ⁻¹
Stroke length:	20 mm
Base plate angle:	-45° – 0° – 45°
Cutting depth in wood:	65 mm
Cutting depth steel:	5 mm
Sound pressure level _{pA} :	85,8 dB(A)
Uncertainty _{pA} :	5 dB(A)
Sound power level _{LWA} :	93,8 dB(A)
Uncertainty _{LWA} :	5 dB(A)

HAND ARM VIBRATION:

Wood _{ah,8} :	13.06 m/s ²
Sheet steel _{ah,8} :	23.14 m/s ²
Uncertainty K:	1.5 m/s ²

BATTERY FBT-CLB014

Voltage:	12 V DC.
Capacity:	2 Ah, 24 Wh

CHARGER FBT-CLC011 (not included)

Input:	220 – 240 V ~ 50–60 Hz, 50 W
Output:	12 V DC.
Charging current:	2400 mA

9.1 CHARGING VIA USB

The battery can be charged via a USB-C charger (5.0 V d.c. input, 1.8 A) and/or a USB port.

NOTICE

» Only the USB cable is included in the delivery.

10 WASTE DISPOSAL AND RECYCLING

10.1 DISPOSING OF THE PACKAGING



Sort the packaging before you dispose of it. Dispose of paperboard and cardboard with the recycled paper service and wrappings with the appropriate collection service.

The product has been packaged to protect it from damage in transit. The packaging is made of materials that can be recycled in an environmentally friendly manner.

Dispose of the packaging such that it is correctly sorted. Submit cardboard and card to waste paper and foils to the recycling collection.

10.2 DISPOSING OF THE PRODUCT



Old products may not be disposed of in the household waste!

Should the product no longer be capable of being used at some point in time, dispose of it in accordance with the regulations in force in your city or county.

This ensures that old products are recycled in a professional manner and also rules out negative consequences for the environment and human health. For this reason, electrical equipment is marked with the symbol shown here.

10.3 BATTERY DISPOSAL



Batteries may not be disposed of with household waste!

As the end user you are required by law to bring all batteries and rechargeable batteries, regardless whether they contain harmful substances* or not, to a collection point run by the city or county, or to a retailer, so that they can be disposed of in an environmentally friendly manner.

*labeled with: Cd = cadmium, Hg = mercury, Pb = lead

11 EC DECLARATION OF CONFORMITY

We hereby declare, **Batavia B.V., Weth. Wassebaliestraat 6d, NL-7951 SN Staphorst**, that the device **Cordless Jigsaw, Model FBT-CJS004**, complies with the relevant fundamental health and safety requirements of the EC directives: **2014/30/EU** (Electromagnetic Compatibility), **2006/42/EC** (Machinery), **2011/65/EU** (RoHS), **(EU) 2023/1542**. The following harmonized standards have been applied for the conformity assessment:

EN 62841-1:2015+A11

EN 62841-2-11:2016+A1+A11

EN IEC 55014-1:2021

EN IEC 55014-2:2021

EN IEC 63000:2018

EN 62133-2:2017+A1:2021

Staphorst, October 19, 2025



Technical documentation retained by:

Jin Min, Batavia B.V., Weth. Wassebaliestraat 6d, 7951 SN Staphorst, Netherlands

The product and operating instructions are subject to change. The technical data may be changed without prior notice.

12 UK DECLARATION OF CONFORMITY

We, the **Batavia B.V., Weth. Wassebaliestraat 6d, NL-7951 SN Staphorst, Netherlands** declare by our own responsibility that the product **Cordless Jigsaw, Model FBT-CJS004**, is according to the basic requirements, which are defined in the UK Regulations Supply of Machinery (Safety) Regulations 2008, Electromagnetic Compatibility Regulations 2016, Restriction of the Use of Certain Hazardous Substances in Electrical and Electronic Equipment Regulations 2012 and their amendments.

Staphorst, October 19, 2025



Jin Min, QA Representative

Batavia B.V., Weth. Wassebaliestraat 6d,
7951 SN Staphorst, Netherlands

13 WARRANTY

Please contact our **AFTER SALES SUPPORT** by phone or e-mail before sending in the product.

This allows us to provide support in the event of possible operator errors.

13.1 WARRANTY CONDITIONS

Dear Customer,

The **ALDI warranty** offers you extensive benefits:

Warranty period: **3 years** from date of purchase.
6 months for wear parts and consumables under normal and proper conditions of use (e.g., rechargeable batteries).

Costs: Free repair/exchange No transport costs

Hotline: 0 1827 438 013 (GB) | 0 124 695 20 (IE)
(standard national landline call rate)

Phone lines available: Mon - Fri 8 a.m. - 7 p.m.

Please contact our **AFTER SALES SUPPORT** by phone or e-mail before sending in the device. This allows us to provide support in the event of possible operator errors.

In order to make a claim under the warranty, please send us:

- The faulty item together with the original purchase receipt
- The product with all components included in the packaging

The warranty does not cover damage caused by:

- **Accident or unanticipated events** (e.g. lightning, water, fire)
- **Improper use or transport**
- **Disregard of the safety and maintenance instructions**
- Other **improper treatment or modification** of the product

After the expiry of the warranty period, you still have the possibility to have your product repaired at your own expense. If the repair or the estimate of costs is not free of charge, you will be informed accordingly in advance.

This warranty does not affect your statutory rights. In the event that a product is received for repair, neither the service company nor the seller will assume any liability for data or settings possibly stored on the product by the customer.





**PRODUCED IN
CHINA FOR** **ALDI STORES LTD.**
PO Box 26,
ATHERSTONE,
WARWICKSHIRE,
CV9 2SH

ALDI STORES (IRELAND) LTD.
PO Box 726,
NAAS,
CO. KILDARE
VISIT US AT WWW.ALDI.COM

MADE IN CHINA

V02/0126